

T.E.(MECHANICAL)(Sem VI) (CBSGS) / 37502 - MACHINE DESIGN - I

Time: 3 Hours

Marks: 80

- Question No. 1 is compulsory.
- Attempt any three questions from the remaining.
- Assumption made should be clearly stated.
- Use of standard Design Data Book by PSG, Mahadevan is permitted.

Q.1Answer any **four** of the following**20**

- 'Ergonomic is compromise in order to achieve performance and aesthetic' explain this statement with example.
- Explain mechanism of fatigue failure in ductile and brittle material.
- Explain overhauling of screw and self-locking of screw.
- What is surge in spring? How it can be eliminated.
- What is the necessity of theories of failures? Name different theories of failures.

Q.2

- Why the cotter in the Cotter joint is kept as weakest part, explain.
- A knuckle joint is to be design to connect two Mild Steel bars under a tensile load of 150 KN. The allowable stresses are 75Mpa in tension, 50Mpa in shear and 150 Mpa in crushing. (Assume empirical relations as Diameter of knuckle pin $d_1 = d$, Outer diameter of eye $d_2 = 2d$, diameter of knuckle pin head and collar $d_3 = 1.5d$, thickness of single eye $t = 1.25d$, thickness of fork $t_1 = 0.75d$, thickness of pin head $t_2 = 0.5d$)

4

- Draw neat sketch of knuckle joint. **3**
- Find the diameter of the rod (d). **2**
- Using empirical find all dimensions. **3**
- With neat sketches for failure cross section areas check all components under different failures. **8**

[PTO]

Q.P. Code: 25532

- Q.3** (a) Show the variation of the tangential stress and radial stress across the cylinder thickness and derive the Lames equation for the thickness of thick cylinder subjected to an internal pressure only. **5**
- (b) A horizontal shaft transmitting 20KW at 120 rpm is supported at the bearing at A at the left end and B at the right end which are 2400mm apart. Gear C and gear D located at a distance of 250mm and 400mm from the Centre line of left and right bearing respectively. The PCD of gear C and D are 600mm and 200mm. The tangential force of the gear C and D are act vertically downward. The weight of gear C and D are 950N and 350N respectively. The combined shock and fatigue factors for bending and torsion are 1.5 and 1.2 respectively. Find the diameter of the shaft if the design stress is 100MPa in tension and 60MPa in shear. Take $F_r = F_t \tan (20^\circ)$ **15**
- Q.4** (a) Design a bush pin type flexible coupling to connect an electric motor with the shaft of centrifugal pump. The motor delivers a power of 20KW at 960 rpm. The diameter of the motor and pump shaft 40mm. Allowable bearing pressure in the rubber bush is 0.45 N/mm^2 . Select standard key and check it for shear and crushing failure. **12**
- (b) Design a Helical valve spring for an operating load range of 600N to 1200N. The compression at the maximum load is 25mm. Take the spring index 6 and permissible endurance shear stress for the spring material as 480Mpa and yield stress in shear is 960MPa and $G = 80\text{KN/mm}^2$. **08**

[PTO]

Q.5 (a) Explain the following terms related to the design of machine elements subjected to the variable loads. **10**

1. Notch sensitivity
2. Endurance limit
3. Surface finish factor
4. Size factor
5. Stress concentration factor

(b) The circular rod is subjected to 700kN tensile to 300kN compressive varying axial load. Find the diameter of the rod using Soderberg criteria and assuming following data. Endurance limit = 280MPa, tensile yield strength = 350MPa, factor of safety = 2, correction factor for loading = 0.7, surface factor = 0.8, size factor = 0.85, stress concentration factor = 1. **10**

Q.6 (a) Select suitable standard hook for the lifting load of 110kN of trapezoidal cross section and find the stress induced at the most critical cross section of the hook. **10**

(b) A bracket is supported by four rivets of equal diameter as shown in figure 1 is used to support a load of 12kN. Determine the size of the rivet taking the permissible shear stress as 60MPa. **10**

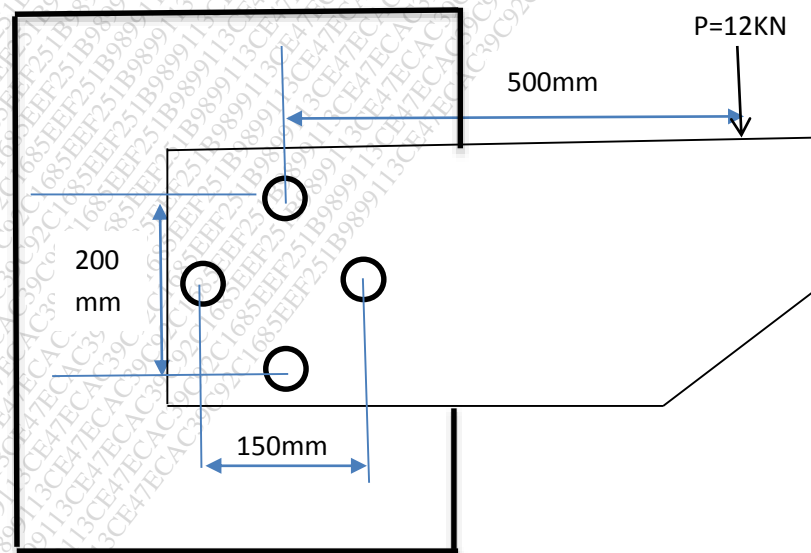

Figure:1