

(Time: 3 Hours)

[Total Marks: 80]

- N.B.:** (1) Question No. 1 is compulsory.
 (2) Solve any three questions from the remaining five.
 (3) Figures to the right indicate full marks.
 (4) Assume suitable data if necessary and mention the same in answer sheet.

- Q.1** Attempt any 4 questions:
- (a) With neat circuit explain the working of comparator circuit. [05]
 (b) Write short note on: Bi FET and Bi MOS differential amplifier circuit. [05]
 (c) Design a circuit with Op Amp, resistors and a capacitor that simulates an inductor of 1 H. [05]
 (d) For a regulated dc power supply the output voltage varies from 12 V to 11.6 V when the load current is varied from 0 to 100 mA which is the maximum value of I_L . If the ac line voltage and temperature are constant, calculate the load regulation, % load regulation and output resistance of the power supply. [05]
 (e) How can the true RMS value of voltage signal to measured using analog multipliers. [05]
- Q.2** (a) Design an adjustable output voltage regulator circuits using IC 317 to give 5 to 12 volts at $I_L=1$ Amp. Given; $I_{ADJ}=100 \mu A$ and let $R_1=240 \Omega$. [10]
 (b) Explain the operation of single slope integrating ADC and state its advantages, disadvantages. [10]
- Q.3** (a) Draw a neat circuit diagram of a RC phase shift oscillator using op-amp. Derive its frequency of oscillation. What are the values of R and C for frequency of oscillation to be 1 kHz? [10]
 (b) Explain the working principle of successive approximation type ADC. [10]
- Q.4** (a) With the help of a neat diagram, input and output waveforms and voltage transfer characteristics explain the working of non-inverting Schmitt trigger. Derive the expressions for its threshold levels. Explain how these levels can be varied? [10]
 (b) Design a differentiator to differentiate an input signal that varies in frequency from 10 Hz to about 500 Hz. Draw its frequency response. If a sine wave of 2 V peak at 500 Hz is applied to the differentiator, write expression for its output and draw output waveform. [10]
- Q.5** (a) Draw the circuit diagram of a square and triangular waveform generator using op-amp. With the help of waveforms at suitable points in the circuit explain its working. Explain how duty cycle can be varied? [10]

- (b) Analyze the circuit given in Fig. 5(b). Draw the waveforms at output terminal v_O and across the capacitor C . Comment on the duty cycle of output waveform. Take diode D as an ideal diode and assume R_A is equal to R_B . [10]

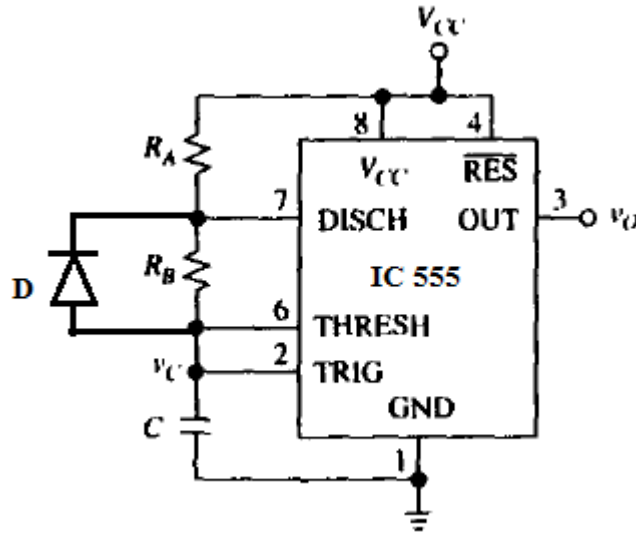

Fig. 5(b)

Q.6

Short notes on: (Attempt any four)

- | | |
|--|------|
| (a) Wilson current source. | [05] |
| (b) Temperature compensated log amplifier. | [05] |
| (c) Wein bridge oscillator. | [05] |
| (d) XR2206 waveform generator. | [05] |
| (e) Switch mode power supply. | [05] |
